

VERITY[®]

7-INCH "S" SERIES SYSTEM Part # SM07S



Just View It[®]

Please read this manual completely before operating the SYSTEM

A division of
Component Solution Services, LLC.
56600 Twin Branch Dr.,
Mishawaka, IN 46545
www.VeritySafe.com

TABLE of CONTENTS

Contents

ABOUT US	3
THINK SAFETY	4
SYSTEM FEATURES.....	6
SYSTEM COMPONENTS	7
MOUNTING.....	8
CABLE CONNECTIONS	9
MONITOR OPERATIONS	10
MENU OPERATIONS	11
SYSTEM DIMENSIONS	14
VERITY® WARRANTY	15
TECHNICAL SUPPORT	16

www.VeritySafe.com

Our tech support is manned by real people in front of all our powered-up systems prepared to knowledgeably talk you through an issue solution – not a person with no knowledge in front of a spreadsheet of prepared phrases. Verity=24/7 support for OEMs and Fleets. This manual does not reflect changes in components to customized systems.



ABOUT US

Component Solution Services LLC engineers the **Verity®** products to meet any requirement and price point within the commercial and fire rescue industries. Designed for professional drivers, Verity develops and markets products and applications to transmit video, audio, and data. Verity® is also home to the **Reveal®** line of MDVRs.



The Verity Difference:

- We are an engineering firm
- Products designed and tested in the USA
- Field-tested, not just bench-tested
- Low issue rate of 0.022%
(That is one component out of 5,000+ systems)
- Not found in Big-Box or online mega-sites
- Easy to reach tech support from our R&D department

Verity integrates the needs of the fleets and end-users into what we engineer for our OEMs

Replacement parts can be found at:
www.Librv.com

THINK SAFETY

Read our manual before operating
or installing this system.

Most likely, your system came pre-installed so the installation section will be for reference.

Thank you for your purchase of our Verity SM07S. When installed and used properly, your SM07S is designed to deliver you years of trouble-free operation. This manual contains important information required to properly install and operate the unit. Verity units are designed for quick installation by trained professionals in proper installation environments. Our designs are based on decades of working with vehicle manufacturers.

Verity products are intended to be installed as a supplement and our observation systems and/or products are not intended for use as substitutes for rear-view mirror devices, or for any other standard motor vehicle equipment which may be required to be installed on vehicles by law. Verity products promote improving the vehicle operator's field of view. Our products are no substitute for proper defensive driving techniques, observance of traffic laws, and motor vehicle safety regulations.

Installation Location

It is unlawful in most locals for any person to drive a motor vehicle equipped with a television viewer/screen located at any point forward of the back of the driver's seat or in any location that is visible, directly, or indirectly to the driver while operating the vehicle. Our systems are designed to be used primarily as a rear observation device.

DO NOT OPEN ANY COMPONENT. There are no serviceable parts inside any of the components of the SM07S. Opening the product will break the tamper indicators and void the warranty.

WARNING

- ◆ Do not place heavy objects on cables or cover them with carpet or mats.
- ◆ Do not place cables where they can be crushed in any manner.
- ◆ Our systems are designed as a driving aid. Watching videos, broadcasts, DVDs and/or any images other than intended driving assistance cameras is prohibited.

CAUTION

- ◆ To avoid damage to the electronic circuit, stop using this product while doing welding work to the vehicle and/or trailers.
- ◆ Never immerse any component in water, and do not employ spray cleaners. When cleaning, use a damp lint-free cloth only.
- ◆ Connect this unit only to other compatible devices.
- ◆ Although our products have built-in surge and cross polarity protection, make sure all cables are connected properly; improper cable connections may damage the camera and the monitor.
- ◆ Cables should not be allowed to touch hot or rotating parts, such as the engine, ventilator, etc.
- ◆ Do not locate the monitor near heat generating vents or devices.
- ◆ Turn off power to the monitor when connecting the camera.

Monitors are not designed to be waterproof. (Our SM07F waterproof monitor is the exception). Exposure to water, such as rain, may damage the unit.

SYSTEM FEATURES

MONITOR SPECIFICATIONS

(Monitor part #MK07S)

- Screen size: 7-inch digital screen (16:9)
- High Resolution: 1024 x 600 Pixel (RGB)
- System: PAL/NTSC Auto select
- Contrast: 400:1
- Brightness: 300 cd/m²
- Power supply: DC 12V~24V with reverse polarity protection
- Operation temperature: -30°~80°C
- Storage temperature: -20°~70°C
- Monitor view angle: Horz. L (70) R (70) Vert. UP (50) DOWN (70)
- 3 AV with shrink tube labeled trigger wires,
- Auto blue screen if no signal on the activated channel.
- Size: 141 x 103 x 25 mm.
- Weight: 418 g.

Features: Removable HD sunshade, LCD screen, LED blue light buttons, high-quality processor, in-line waterproof fuse, easy-to-use OSD menu function via buttons: reversing image delay time 0~10s, Mirror/Normal image, plus horizontal flip, multi-language.

CAMERA SPECIFICATIONS

(Camera Part #C001S)

- Horizontal Resolution: 600 TV Lines
- TV System: NTSC
- Image Type: 1/3 Inch Color CCD Sharp® (or equivalent)
- Effective Pixel: 510 x 492
- Illumination: 0 Lux (built-in 8 IR LEDs for night vision)
- Aluminum Housing
- Waterproof: IP67
- Power Supply: DC 12V (powered from the monitor)
- Operating Temperature: -20°C ~ +75°C
- Viewing Angle: 170-degree diagonal / 90-degrees horizontal
- Includes camera mounting bracket

SYSTEM COMPONENTS



7-Inch digital
LCD monitor



Manual



Weatherproof Camera
with night vision



20-Meter Camera
Cable



13-pin to 4-pin Monitor
Harness



Fan Style Mount

MOUNTING

This monitor can be mounted on the dash and on horizontal and vertical surfaces. Make sure the view is suitable for the driver to observe the images. Take care not to block any necessary viewing area when mounting. Before mounting the system, permanently hook up all connections to ensure proper operation.

Monitor Mounting

- After determining the monitor location, position the monitor support bracket, mark the bolt hole location, and drill the holes. Be careful not to drill into any other surface where wires and components may be hidden.
- Attach monitor Fan Bracket
- Connect one end of the power cable (wire) to the proper connections. Connect the other end of the power cable (plug) to the monitor; connect the monitor and the camera with the 13-pin system connecting the cable. (see page 9)

Camera Connection

Do NOT make the cable tight from the back of camera going into the truck

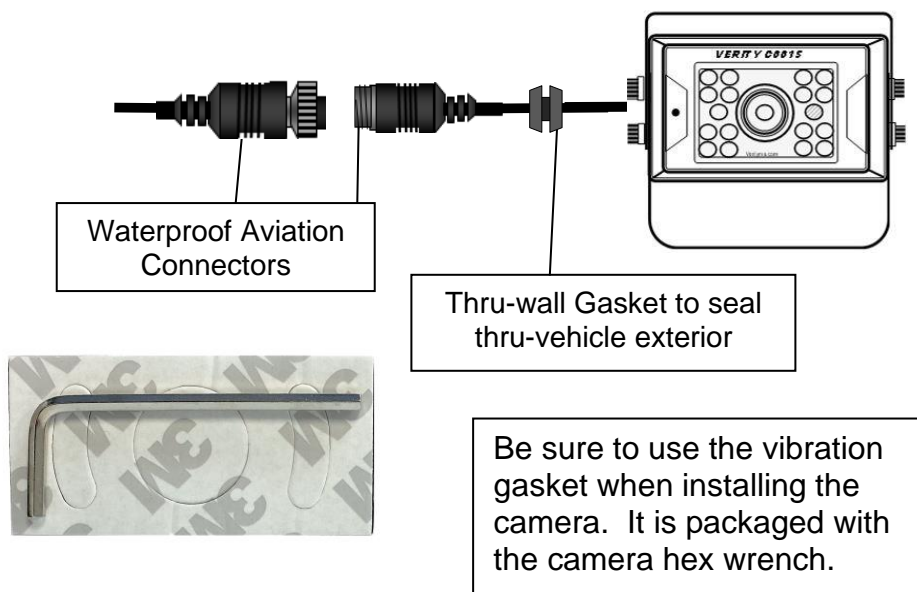

CABLE CONNECTIONS

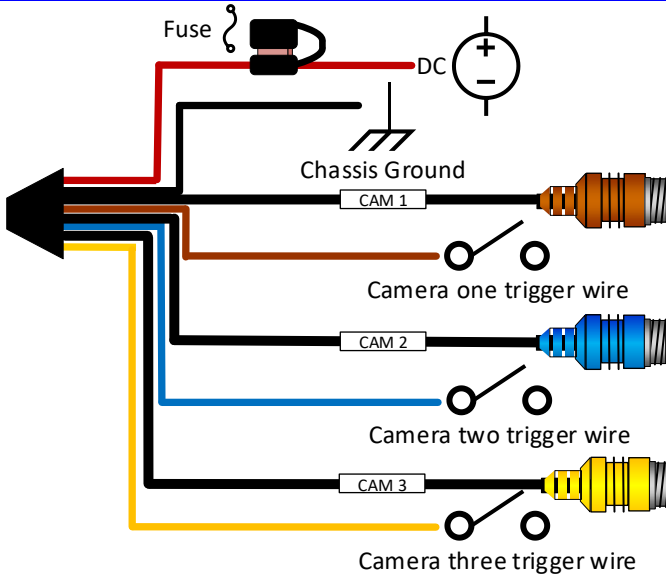

Wire Connection Key:

- ◆ **RED** wire to ignition hot (+) 10-26 volts
- ◆ **BLACK** wire to ground (-) (please use a chassis ground post)
- ◆ **BROWN trigger wire is for camera 1.** Connects brown trigger wire to backup light wire or backup beeper wire. This connection is needed to activate the monitor when putting the vehicle into reverse.
- ◆ **BLUE** (CAM 2) trigger wire for accessory cameras (side cameras etc.) **DO NOT** power this wire unless you intend to trigger a second camera. It will be connected to your trigger power source, such as a turn signal light wire.
- ◆ **YELLOW** (CAM3) trigger wire for accessory cameras (side cameras etc.) **DO NOT** power this wire unless you intend to trigger a third camera



MONITOR OPERATIONS

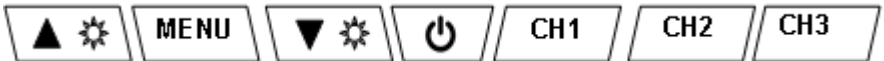
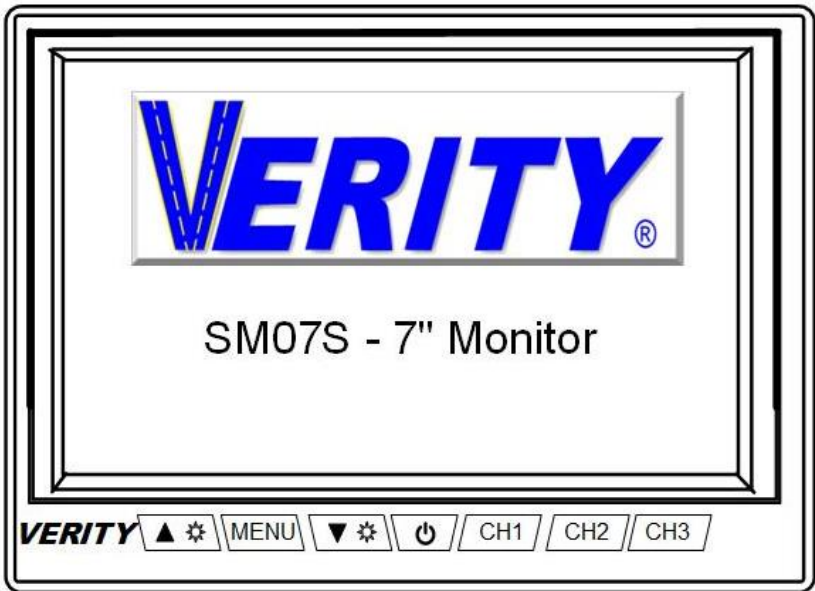

Buttons from left to right

1. (VOL+) Volume Increase Up Arrow
2. Menu Control Button
3. (VOL-) Volume Decrease Down Arrow
4. Power Off/On button - Red color is stand-by- Blue is powered
5. Channel / Camera 1
6. Channel / Camera 2
7. Channel / Camera 3

Monitor will turn on automatically if trigger wire is activated.

Menu Press 6 times

ZOOM Toggles between 16:9 / 4:3 image sizes

Menu Press 7 times

“FLIP” Image Orientation:

This selection flips each camera image individually both horizontally and vertically. This allows for a correct image of interior/forward-facing cameras.



Menu Press 8 times

LANG (LANGUAGE): “Show English as the primary language.”
Displays on the screen.

LANG

ENGLISH

Menu Press 9 times

Delay time monitor stays on after the trigger wire is deactivated. It can be set to 0, 1, 2, 3, 4, 5, 6, 7, 8, 9, 10-second delays.

Delay 0 (camera 1) Delay 3 (camera 2 & 3)

SIDE CAMERA HOOK UP – when adding a side camera, set that camera delay to 3 seconds.

Menu Press 10 times

Auto-dimming function
Displays on the screen.

DIMMER

ON

Menu Press 11 times

Parking line functions

Displays on the screen.

PARK OFF

When the parking line function is on the backup lines can be adjusted. (See section below)

Menu Press 12 times - Resets the monitor back to factory defaults

Displays on the screen.

RESET

Adjusting Parking Lines

Step One: keep the engine off and turn ignition to accessory mode.

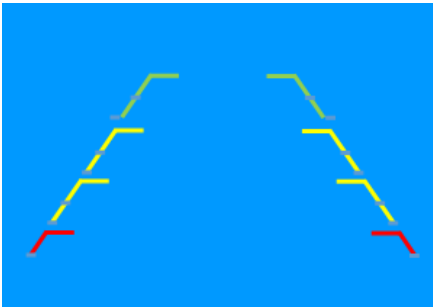

Default Screen

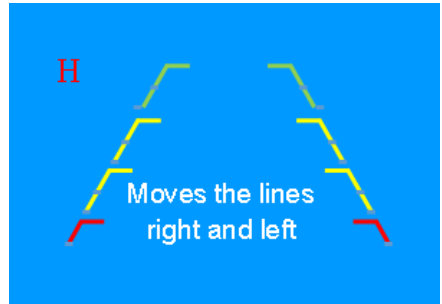

Horizontal Adjustment

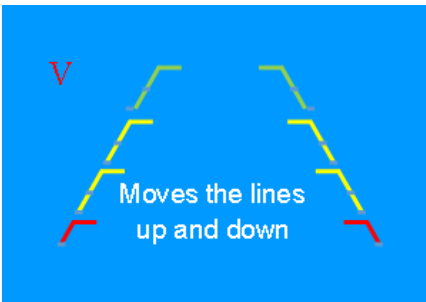

Vertical Adjustment

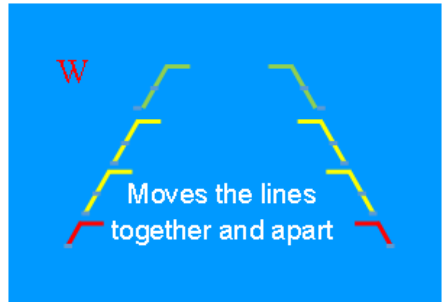

Width Between Lines

SYSTEM DIMENSIONS

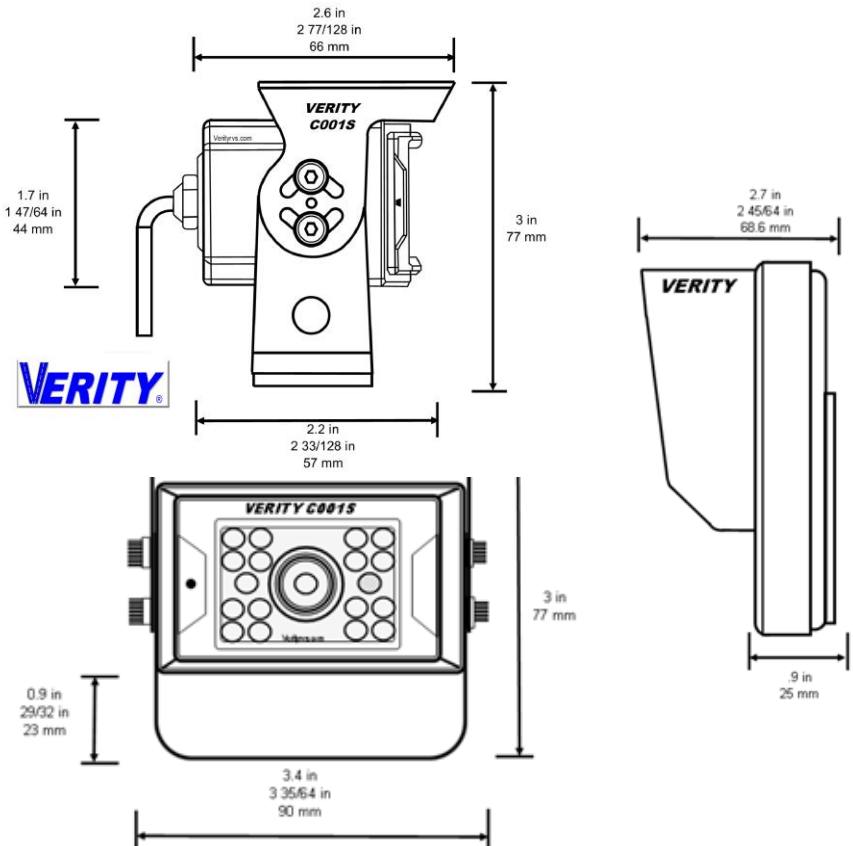
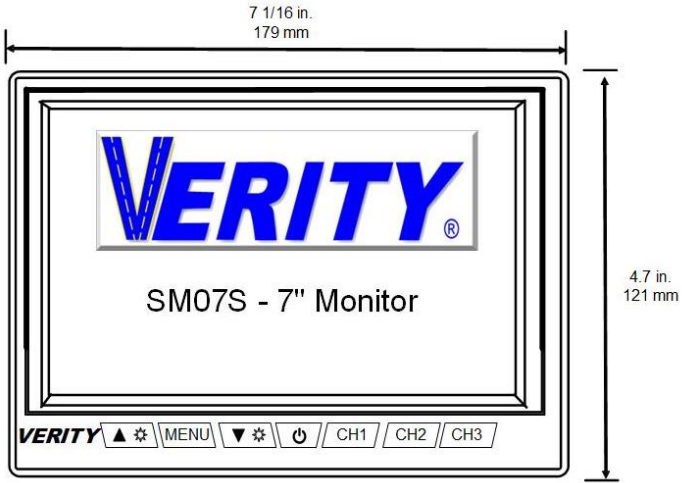

Verity®
A division of
COMPONENT SOLUTION SERVICES, LLC (CSS)
LIMITED One (1) YEAR WARRANTY

1. CSS products' warranties are not transferable. They apply to the consumer for one (1) year and cover defects in material and workmanship. We do not warranty our cables, which are QC tested at three different stations before shipping. All components must be installed in compliance with all Federal, State, and Local government requirements. The warranty is limited to the United States of America and Canada.

2. Defective components will be replaced or repaired based on a CSS evaluation of the component. Inbound shipping charges, based on the CSS rate allocated in the RMA (returned merchandise agreement), will be covered once the component has been deemed defective. The pre-assigned inbound freight will be supplied upon the return of the product. All repaired/replaced warranty parts shall be for the remaining duration of the original warranty period.

3. CSS takes pride in our products and will aid in the processing of your components:

a) All warranty claimants must have consulted our technical support department for troubleshooting and acquiring an RMA. Contact can be made via email at tech@veritysafe.com or call 574-807-6002.

b) When the warranty claim is made, the consumer must establish the warranty start dates by presenting documentation regarding the date of retail purchase (e.g., bill of sale).

c) Service performed by non-authorized service personnel may void all warranty claims.

d) CSS will make no payments for system removal/system re-installing, mileage allowance, or transportation expenses. Verity does not pay for labor.

The limited warranty does not cover damage resulting from misuse, accident, modification, or alteration to hardware or software, tampering, unsuitable physical or operating environment beyond product specifications, improper maintenance, or failure caused by a product for which CSS is not responsible. There is no warranty for any product with removed or altered identification labels. **CSS DOES NOT PROVIDE ANY OTHER WARRANTIES OF ANY KIND, INCLUDING, BUT NOT LIMITED TO, THE IMPLIED WARRANTIES OR CONDITIONS OF MERCHANTABILITY AND FITNESS FOR A PARTICULAR PURPOSE. SOME JURISDICTIONS DO NOT ALLOW THE LIMITATION OF IMPLIED WARRANTIES, SO THIS LIMITATION MAY NOT APPLY TO YOU.**

4. This warranty gives you specific legal rights; you may also have other rights that vary from state to state.

Technical Support

A service ticket can be filled out online to supply the quickest service. The service ticket can be easily found on our website, www.VeritySafe.com, or use the code to the right. Please have the system's serial number, which is found on the back of the monitor, when contacting the service department. We take great pride in delivering the most dependable product in the industry. Each item was 100% QC tested, and then we randomly recheck another up to 10% before it leaves our hands to you. We have a 0.022% factory issue rate with our products.

Email Tech Support: Tech@VeritySafe.com

Phone Tech Support: 574-807-6002

Note: if you are a fire/rescue customer needing tech support after hours or on weekends, leave a message, and a technician will return your call as soon as one becomes available.



VERITY[®]

a division of

Component Solution Services, LLC.

56600 Twin Branch Drive

Mishawaka, IN 46545

574-807-6002

Toll-Free 844-875-4799

We at Verity would like to personally thank you for purchasing our product. Our company strives to supply the best products at a fair price. We care that you enjoy a safe driving experience.

2019-Current

Verity[®]

Content copyright protected.

Revision 25 NF