

Components:

- (1) MK07B Monitor w/ monitor harness
- (1) ADD22H Heavy Duty Mount
- (1) Remote
- (1) Manual

Wiring for constant on

Red wire to Ignition hot (+) 10-24v. DC
Turn on truck. Turn on monitor with remote. Shut truck off with monitor on. Monitor is set to turn on with the truck.
Suggestion: "DIMMER" mode be set to AUTO so monitor dims automatically at night.

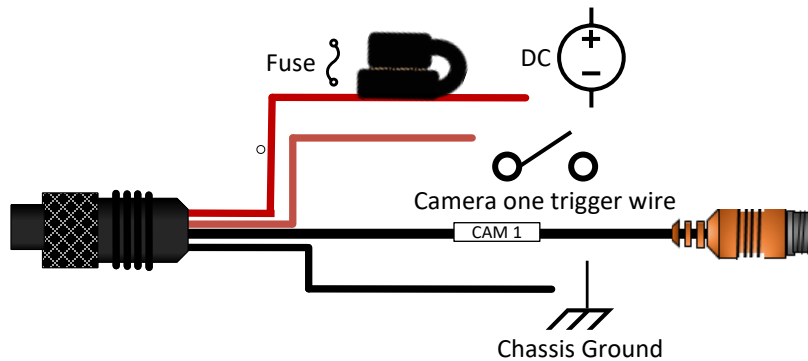

Wire Connection Key

For trucks that cannot be shut off in reverse:

- Red wire** to Ignition hot (+) 10-24v. DC
- Brown trigger wire** for camera 1
- Black wire** to ground block or ground post GND (-)

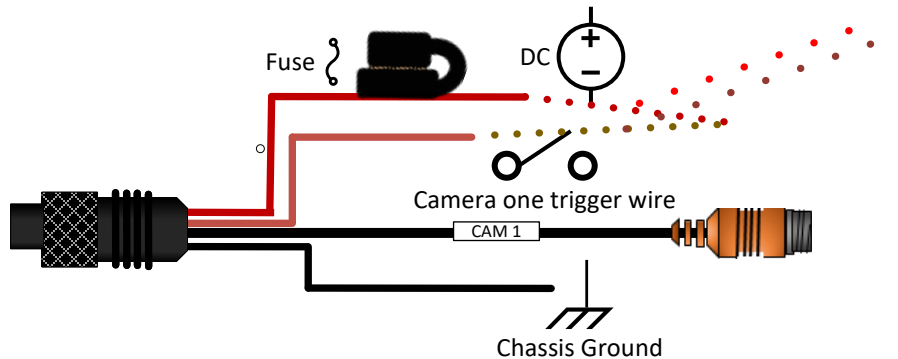

Note: if truck can be shut off in reverse, use these connections. Connect Red and Brown wires together and attach to reverse triggered power