



4.3 INCH
MIRROR MONITOR SYSTEM
Clip-on or Post Mount
Part # SM04



Just View It!

®

Please read this manual completely before operating the SYSTEM

A division of
Component Solution Services, LLC.
56600 Twin Branch Dr.,
Mishawaka, IN 46545
www.verityrvs.com



© 2017 Verity Rear Vision Systems



Just View It![®]

www.VerityRVS.com

© 2019 Verity Rear Vision Systems

Component Solution Services LLC., offers the **Verity Rear Vision Systems**[®] to meet any requirements and price point within the trucking, specialty vehicles, and RV industry. Verity Rear Vision Systems[®] is also home to the Supreme View[®] line of specialty format systems. Our standard cabled systems offer unparalleled features into the trucking and RV industries. Designed for professional drivers, Verity Rear Vision Systems develops and markets products and applications to transmit video, audio, and data either individually or in any and all combinations. The company has also developed, manufactured, and marketed different kinds of personal and vehicle video cameras, DVRs, and accessories for the commercial transportation, fire/rescue, and marine OEM markets.

Think Safety
First

Read our manual before operating
or installing.

Most likely, your system came preinstalled so the installation section would be for reference.

Thank you for your purchase of our Verity Rear Vision Systems®. When installed and used properly, your monitor is designed to deliver you years of trouble-free operation. This manual contains important information required to properly install and operate the unit. Verity Rear Vision Systems® are designed for quick installation by trained professionals in proper installation environments. Our designs are based on decades of working with vehicle manufacturers.

Verity Rear Vision Systems® products are intended to be installed as a supplement and our observation systems and/or products are not intended for use as substitutes for rear-view mirror devices, or for any other standard motor vehicle equipment which may be required to be installed on vehicles by law. Verity Rear Vision Systems® products promote improving the vehicle operator's field of view. Our products are no substitute for proper defensive driving techniques, observance of traffic laws and motor vehicle safety regulations.

Installation Location

It is unlawful in most locals for any person to drive a motor vehicle equipped with a television viewer/screen located at any point forward of the back of the driver's seat (or in any location that is visible, directly or indirectly), to the driver while operating the vehicle. Our systems are designed to be used primarily as a rear observation device.

DO NOT OPEN ANY COMPONENT. There are no serviceable parts inside any of the components of the Verity Rear Vision Systems® products. Opening the product will break the tamper indicators and void the warranty. Contact our tech support if a problem should arise 574-807-6002. For faster response, fill out a service ticket found on our website tech support section. www.verityrvs.com

WARNING

- ◆ Do not place heavy objects on cables or cover them with carpet or mats.
- ◆ Do not place cables where they can be crushed in any manner.
- ◆ Our systems are designed as a driving aid. Watching videos, broadcasts, DVDs and/or any images other than intended driving assistance cameras is prohibited.

CAUTION

- ◆ To avoid damage to the electronic circuit, stop using this product while doing welding work to the vehicle and/or trailers.
- ◆ Never immerse any component in water, and do not employ spray cleaners. When cleaning, use a damp lint-free cloth only.
- ◆ Connect this unit only to other compatible devices.
- ◆ Although our products have built-in surge and cross polarity protection, make sure all cables are connected properly; improper cable connections may damage the camera and the monitor.
- ◆ Cables should not be allowed to touch hot or rotating parts, such as the engine, ventilator, etc.
- ◆ Do not locate the monitor near heat generating vents or devices.
- ◆ Turn off power to the monitor when connecting the camera.

Monitors are not designed to be waterproof. (Our SM07F waterproof monitor is the exception.) Exposure to water, such as rain, may damage the unit.

SYSTEM FEATURES

MIRROR MONITOR SPECIFICATIONS

4.3" digital panel rear view mirror monitor

System: NTSC

2 labeled AV inputs

AV 2 can be triggered

Brightness: 500

Contrast ratio: 400:1

Power voltage: DC12-24V

Operating temperature: -20~70 deg

Storage temperature: -30~80 deg

Combines normal/mirror image

Special anti-glaring treatment

This monitor fits 70%-80% of GM, Ford, and Toyota vehicle's windshield clips

Simple operation

Auto dimming

CAMERA SPECIFICATIONS

Aluminum housing

CCD Camera, 2.9mm lens

Waterproof IP 69

6 IR Night vision

System: NTSC

Pixel: 628 X 582 RGB

View Arrange: 120°



SYSTEM COMPONENTS



4.3 -Inch Mirror Monitor



Monitor Cable



120° Camera



65 foot
Camera Cable



Manual



Mounting Slug

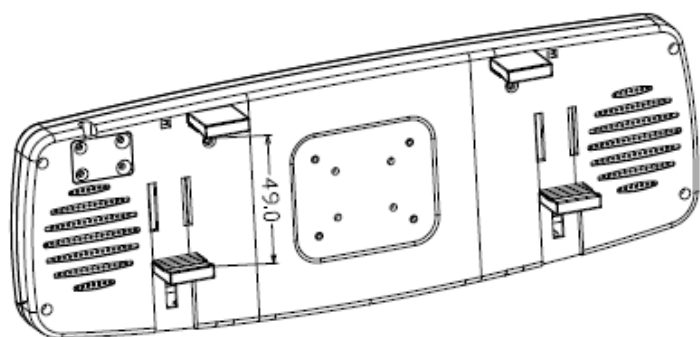
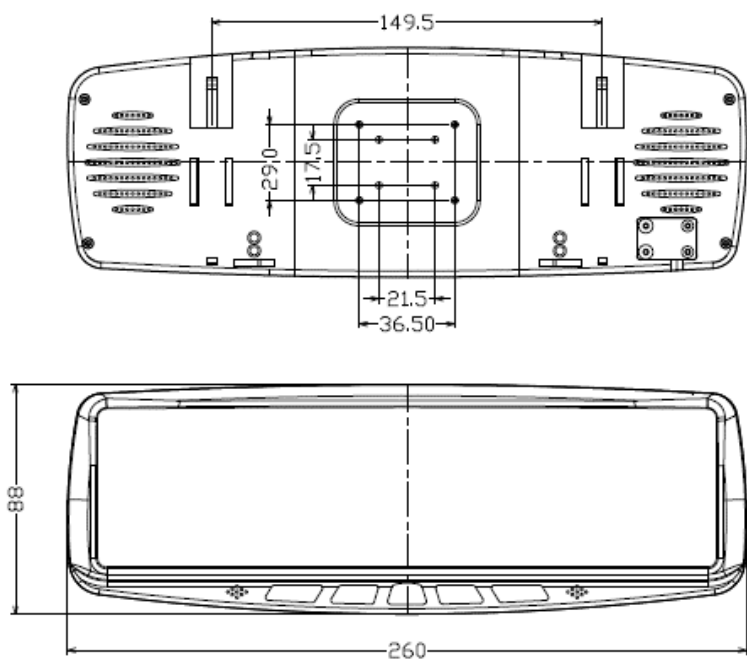

All in .mm
Subject to change.

SYSTEM COMPONENTS

This monitor can be mounted in place of the rear-view mirror. Make sure the view is suitable to the driver to observe the images. Take care not to block any necessary viewing area when mounting. Before mounting the system, permanently hook up all connections to ensure proper operation. This monitor can also be clipped over an existing mirror monitor.

Mounting Monitor

1. Carefully detach the original rear view mirror in the vehicle. Leave the original mounting slug on the windshield.
2. Slide the new monitor bracket over the existing mount point on the windshield. If there is a problem with compatibility, a new mounting slug has been provided that will fit the monitor bracket. Glue the flat side of the slug to the windshield with the narrow end pointing up. Slide the monitor bracket over the new mount point, and tighten the set screw in the mount until snug. Do not overtighten.
3. Connect one end of the power cable (wire) to the proper connections. Connect the other end of the power cable (plug) to the monitor; connect the monitor and the camera with the system connecting cable.

Post Bracket



or Clip-on



CONNECTION OPERATIONS



Verity Rear Vision Systems Wire Connection Key

4-pin camera connectors & trigger wires

Camera 2 (Green trigger wire

Red wire to key-on hot (+) 12-32v. DC (fused)

Black wire to GND. (-)

Green wire to positive back-up light

BE SURE TO ALIGN MONITOR CABLE CONNECTION

If force is applied to this connection when not aligned, it may damage plug pins and void the warranty.

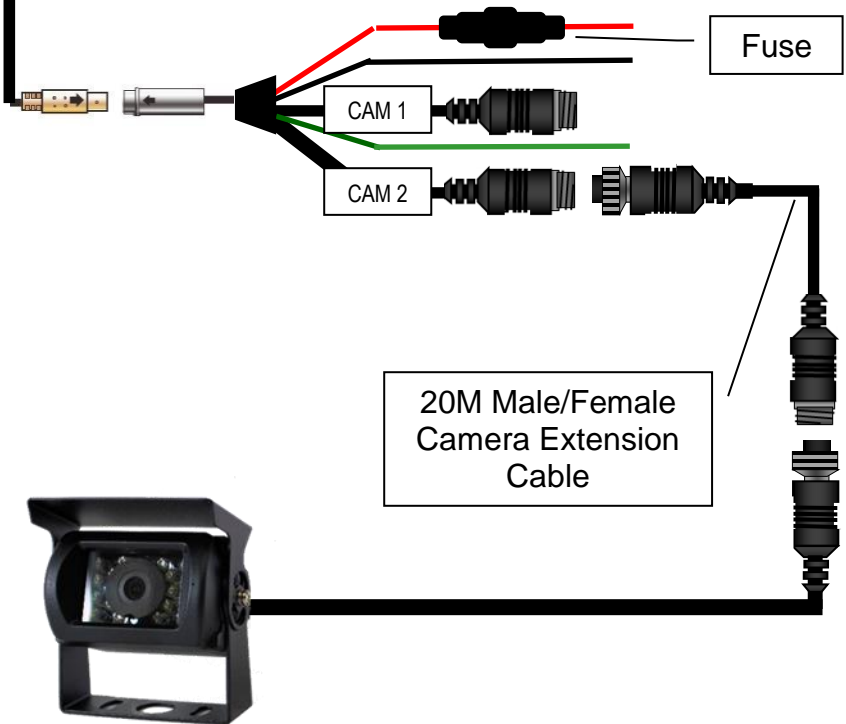

MENU OPERATIONS

Menu:

BRIGHTNESS



Use DOWN / UP arrows to adjust brightness

CONTRAST



Use DOWN / UP arrows to adjust contrast

COLOR

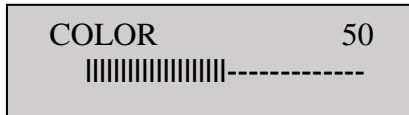

Use DOWN / UP arrows to adjust color

RESET

Restores all preset factory settings

Verity Rear Vision Systems
A division of
COMPONENT SOLUTION SERVICES (CSS)
LIMITED ONE (1) YEAR WARRANTY

1. CSS products' warranties are not transferable. The warranties apply to the retail consumer for one (1) year and covers against defects in material and workmanship.

2. Defective components will be replaced or repaired, based on a CSS evaluation of the component. In-bound shipping charges, based on the CSS rate allocated in the RMA (returned merchandise agreement), will be covered once the component has been deemed defective at the CSS warranty facility. The pre-assigned in-bound freight will be supplied upon return of product. All repaired/replaced warranty parts shall be for the remaining duration of the original warranty time period.

3. CSS takes pride in our products and will aid in the processing of your components:

a) All warranty claimants must have consulted our technical support department for trouble shooting and the acquiring of an RMA.

Contact can be made via email at tech@verityrvs.com or call 574-807-6002.

b) When the warranty claim is made, the consumer must establish the warranty start dates by presenting documentation regarding the date of retail purchase (e.g., bill of sale). c) Service performed by non-authorized service personnel may void all warranty claims.

d) CSS will make no payments for system removal / system re-installing, mileage allowance, or transportation expenses.

The limited warranty does not cover damage resulting from misuse, accident, modification or alteration to hardware or software, tampering, unsuitable physical or operating environment beyond product specifications, improper maintenance, or failure caused by a product for which CSS is not responsible. There is no warranty for any product with removed or altered identification labels. **CSS DOES NOT PROVIDE ANY OTHER WARRANTIES OF ANY KIND, INCLUDING, BUT NOT LIMITED TO, THE IMPLIED WARRANTIES OR CONDITIONS OF MERCHANTABILITY AND FITNESS FOR A PARTICULAR PURPOSE. SOME JURISDICTIONS DO NOT ALLOW THE LIMITATION OF IMPLIED WARRANTIES, SO THIS LIMITATION MAY NOT APPLY TO YOU.**

4. This warranty gives you specific legal rights, and you may also have other rights that vary from state to state.

Technical Support

A service ticket can be filled out online to supply the quickest service. The service ticket can be easily found on our web site www.verityrvs.com or use the code to the right. Please have the serial number of the system which is found on the back of the monitor when contacting the service department. We take great pride in delivering the most dependable product in the industry. Each item was 100% QC tested and then we randomly recheck another up to 10% before it leaves our hands to you.



Email Tech Support: Tech@verityrvs.com

Phone Tech Support: 574-807-6002

Note: if you are a fire/rescue customer in need of tech support after hours or on weekends, leave a message and a technician will return your call as soon as one becomes available.



a division of

Component Solution Services

56600 Twin Branch Drive

Mishawaka, IN 46545

574-807-6002

Toll Free 844-875-4799

We at Verity Rear Vision Systems would like to personally thank you for purchasing our product. Our company strives to supply the best products at a fair price. We care that you enjoy a safe driving experience.